

hydraulic piston pumps for trucks

XA
SAE Series

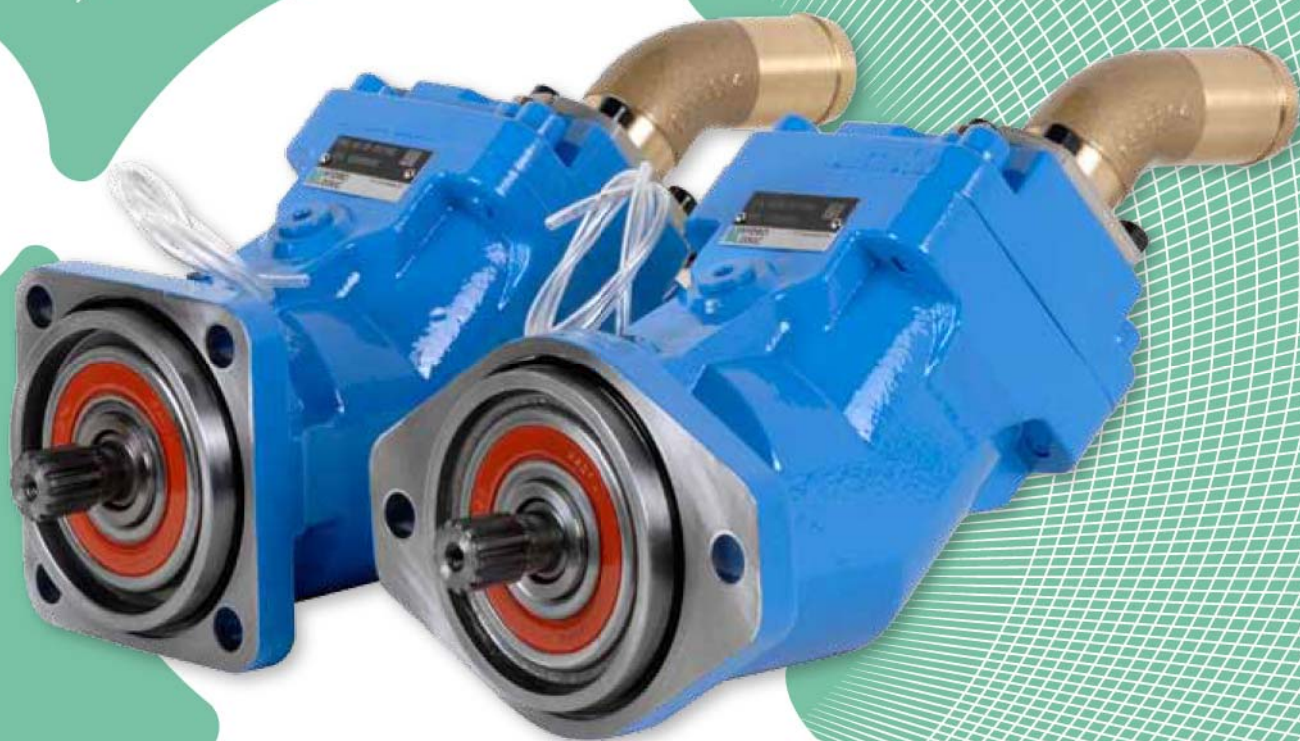

**HYDRO
LEDUC
TOHIO**

Contents

XA series pumps

■ A complete SAE range	1
■ Design of XA series pumps.....	2
■ Range and characteristics	3
■ Dimensions	4
■ Performance.....	5
■ Accessories	6
■ Shaft sealing	7
■ Installation and start-up recommendations.....	8
■ Other LEDUC product lines	9

PA-PAC Series

The HYDRO LEDUC range for truck pumps also includes in-line piston pumps in single flow and twin-flow models.
Literature on request or on our website : www.hydroleduc.com



TXV Series



HYDRO LEDUC also manufactures a range of variable displacement pumps with Load Sensing control for truck hydraulics applications: the TXV series. Models from 2.44 to 7.93 cu.in. (40 to 130cc) in extremely compact size envelopes.
Literature on request or on our website : www.hydroleduc.com



HYDRO LEDUC
Head Office & Factory
BP 9
F-54122 AZERAILLES (FRANCE)
Tel. +33 (0)3 83 76 77 40
Fax +33 (0)3 83 75 21 58

A complete SAE range to suit all applications

HYDRO LEDUC, a specialist in the design and manufacture of high pressure hydraulic components offers a complete range of piston pumps to specifically meet the needs of the truck hydraulics market.

- Fixed displacement bent axis design pumps;
- Fixed displacement in-line piston pumps, single and twin-flow;
- Variable displacement pumps with load sensing control.

Fixed displacement “bent axis” design pumps.

- Endurance
- Silence
- Adaptability

SAE flanges and shafts (J744) and US ports.



XA
SAE Series

The X series also exists for European mount configurations to DIN 5462 (shaft) and ISO 7653 (flange). Literature on request or on our website: www.hydroleduc.com.

Design of XA series pumps

The XA range pumps are designed for the most severe working conditions in terms of :

- space available ;
- drive speed of the pump ;
- power required.

To meet such performance criteria, HYDRO LEDUC opted for the "bent axis" concept, and optimized the pump design in several ways :

- 7 pistons ;
- original idea for plate – barrel synchronisation ;
- change of direction of rotation by simply changing a fitting ;
- use of materials with high mechanical resistance ;
- reinforced sealing.

The XA pumps therefore offer exceptional performance :

- greatly reduced noise levels ;
- high rotating speeds ;
- simple to use ;
- long service life.

The exceptional compacity of the XA pumps, together with their technology, means they can be installed in the most challenging size envelopes and where rotating speed – due to the PTO ratio for example – is high.

Please note :

For all installations where flow can return back to the pump, a check valve must be included on pump output line to protect the pump.

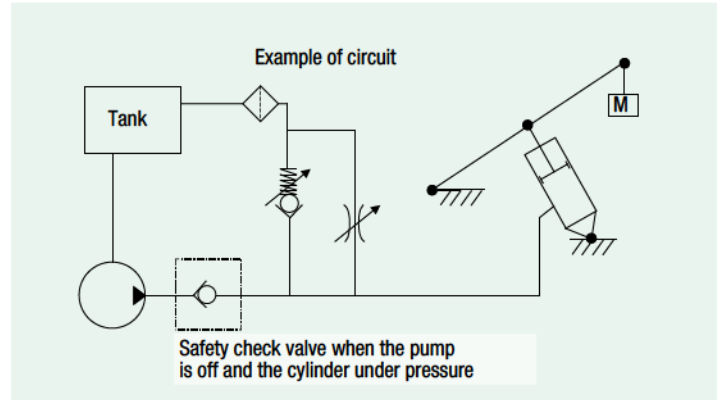

Range and characteristics XA series pumps

6 models

- from 1.1 to 3.84 cu.in. (18 to 65 cc)
- 5075 psi (350 bar) continuous working pressure
- 5800 psi (400 bar) peak pressure
- maximum speed from 2,300 to 2,900 rpm

Minimum size envelope
High rotating speeds
High output pressure

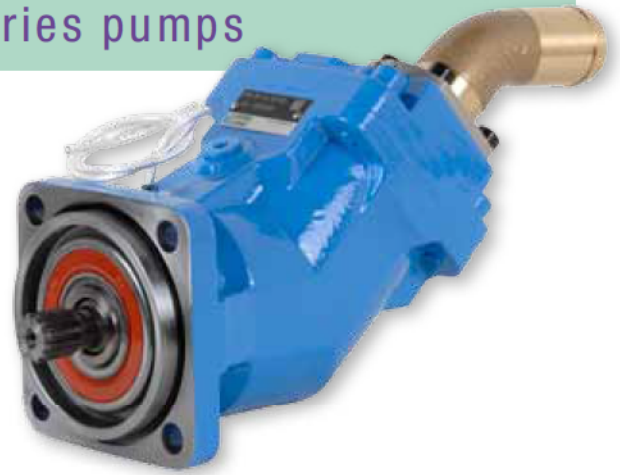

Pump reference	Displacement		Maximum continuous pressure	Maximum intermittent peak pressure	Maximum rotating speed at absolute pressure 14.51 psi / 1 bar	Maximum torque absorbed at 5077 psi (350 bar)		Weight	
	Cu.In	(cc)	psi (bar)	psi (bar)	rpm	lbf ft	Nm	lbs	kg
XA18	1.1	(18)	5075 (350)	5800 (400)	2900	78.9	107	22.48	10.2
XA25	1.52	(25)	5075 (350)	5800 (400)	2650	109.1	148	22.48	10.2
XA32	1.95	(32)	5075 (350)	5800 (400)	2700	140.1	190	22.48	10.2
XA41	2.5	(41)	5075 (350)	5800 (400)	2500	179.2	243	22.48	10.2
XA50	3.07	(50.3)	5075 (350)	5800 (400)	2500	215.3	292	26.01	11.8
XA63	3.84	(63)	5075 (350)	5800 (400)	2300	266.9	362	26.01	11.8

How to change the direction of rotation of the pump

All LEDUC XA pumps are supplied for Clockwise rotation (CW) unless otherwise specified on each purchase order.

To check in which direction the pump should rotate on your installation:

- check the direction of rotation of the PTO;
- if the PTO turns clockwise, the pump must rotate counter-clockwise, and vice versa.

To change the direction of rotation of your XA pump:

- remove the inlet fitting (2) and the 2 parts of the split flange (3).
- remove the rotation setting screw (1).
- remove the plug (6).
- put the rotation setting screw (1) where the plug (6) was, and the plug (6) where the rotation setting screw (1) was.
- put seal (5) on the inlet fitting, then the inlet fitting on the side where the plug (6) is, and fix with the split flange. Tighten with the screws (4).

Tightening torque of rotation setting screw (1) in lbf ft.

Tightening torque of fixation screws (4) in lbf ft.

Tightening torque of plug (6) in lbf ft.

Tip 1: The rotation setting screw is always on the output side. Once the rotation setting screw has been installed, the inlet fitting can no longer be assembled on that side.

Tip 2: Only one tool is needed to change the direction of rotation : a size 6 Allen key.

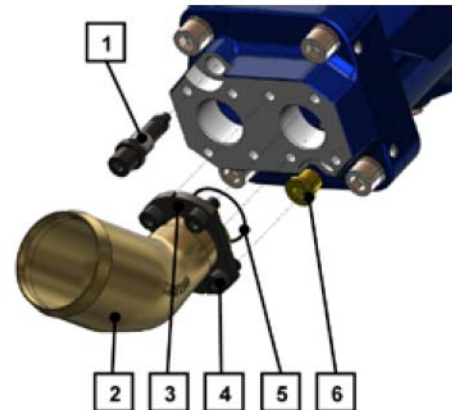

Dimensions XA series pumps

Dimensions

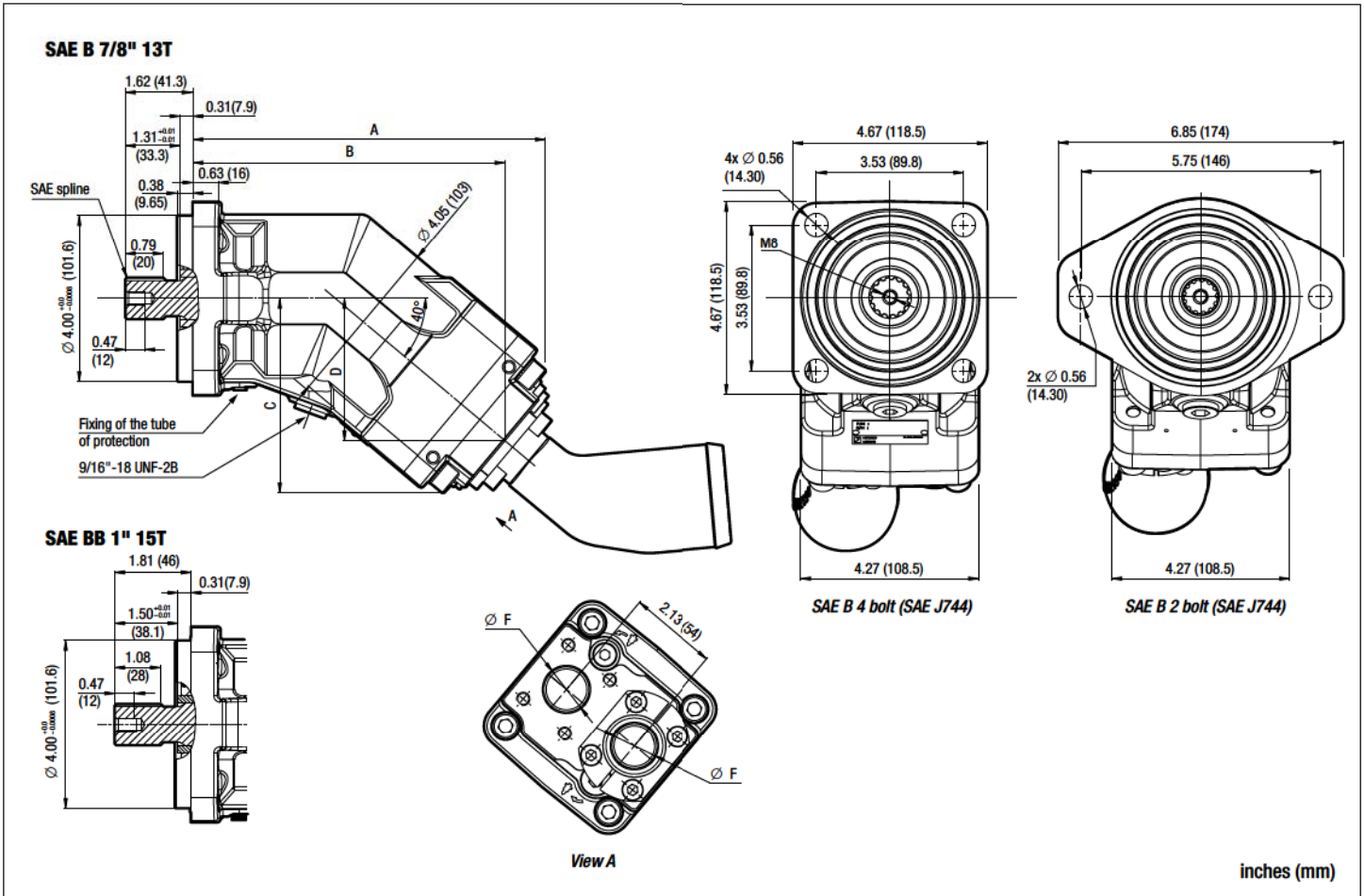

SAE B 2-bolt mounting configurations (SAE J744).

Pump reference	A	B	C	D	F	Shaft
XA18 0517565	7.76 (197.2)	6.79 (172.5)	4.08 (103.7)	2.87 (73)	3/4"-16 UNF-2B	SAE B 7/8" 13T-16/32DP
XA25 0517555	7.76 (197.2)	6.79 (172.5)	4.08 (103.7)	2.87 (73)	3/4"-16 UNF-2B	SAE B 7/8" 13T-16/32DP
XA32 0517545	8 (203.2)	7.03 (178.5)	4.28 (108.7)	3.03 (77)	3/4"-16 UNF-2B	SAE B 7/8" 13T-16/32DP
XA41 0517535	8 (203.2)	7.03 (178.5)	4.28 (108.7)	3.03 (77)	1 1/16"-12 UNF-2B	SAE B 7/8" 13T-16/32DP

SAE B 4-bolt mounting configuration (SAE J744).

Pump reference	A	B	C	D	F	Shaft
XA18 0517560	7.76 (197.2)	6.79 (172.5)	4.08 (103.7)	2.87 (73)	3/4"-16 UNF-2B	SAE B 7/8" 13T-16/32DP
XA25 0517550	7.76 (197.2)	6.79 (172.5)	4.08 (103.7)	2.87 (73)	3/4"-16 UNF-2B	SAE B 7/8" 13T-16/32DP
XA32 0517540	8 (203.2)	7.02 (178.5)	4.28 (108.7)	3.03 (77)	3/4"-16 UNF-2B	SAE B 7/8" 13T-16/32DP
XA41 0517530	8 (203.2)	7.02 (178.5)	4.28 (108.7)	3.03 (77)	1 1/16"-12 UNF-2B	SAE B 7/8" 13T-16/32DP
XA50 0517520	8.45 (214.7)	7.48 (190)	4.65 (118.2)	3.4 (86.5)	1 1/16"-12 UNF-2B	SAE B 7/8" 13T-16/32DP
XA63 0517510	8.45 (214.7)	7.48 (190)	4.65 (118.2)	3.4 (86.5)	1 1/16"-12 UNF-2B	SAE B 7/8" 13T-16/32DP
XA50 0517525	8.45 (214.7)	7.48 (190)	4.65 (118.2)	3.4 (86.5)	1 1/16"-12 UNF-2B	SAE BB 1" 15T-16/32DP
XA63 0517515	8.45 (214.7)	7.48 (190)	4.65 (118.2)	3.4 (86.5)	1 1/16"-12 UNF-2B	SAE BB 1" 15T-16/32DP

Performance XA series pumps

Torque absorbed as a function of pump output pressure

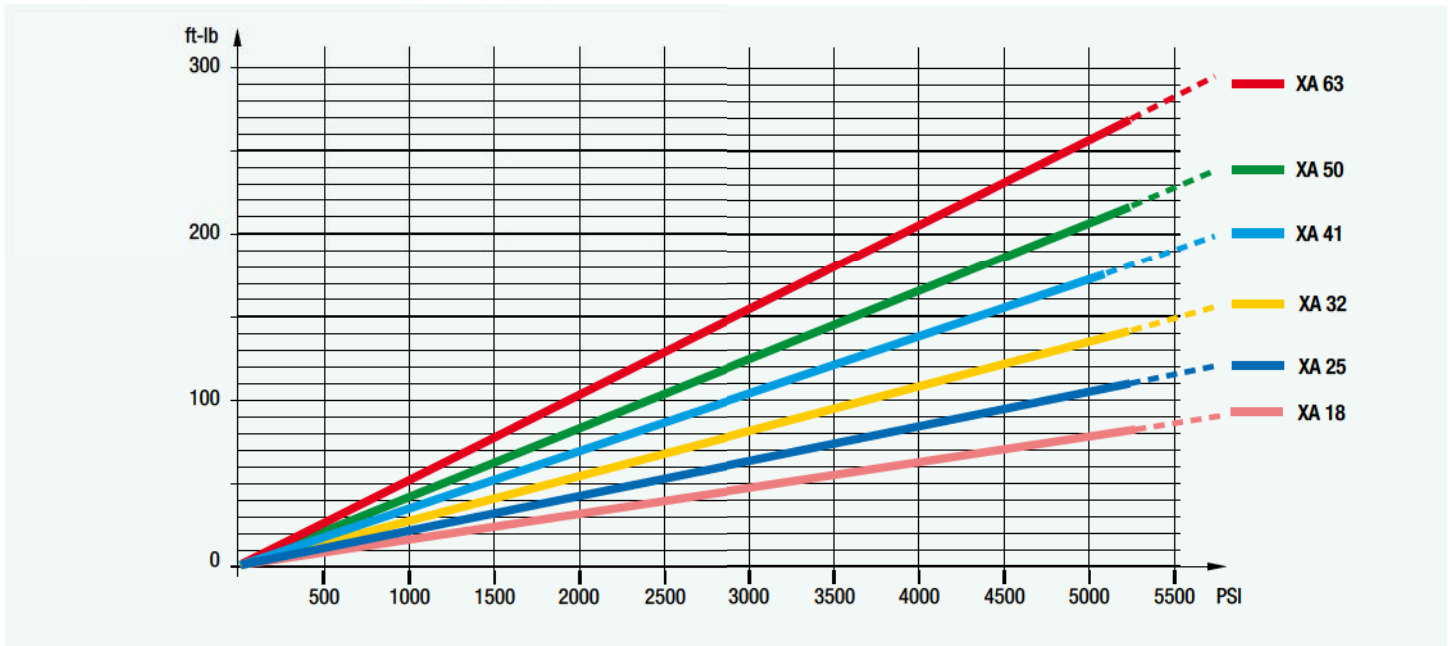

Flow

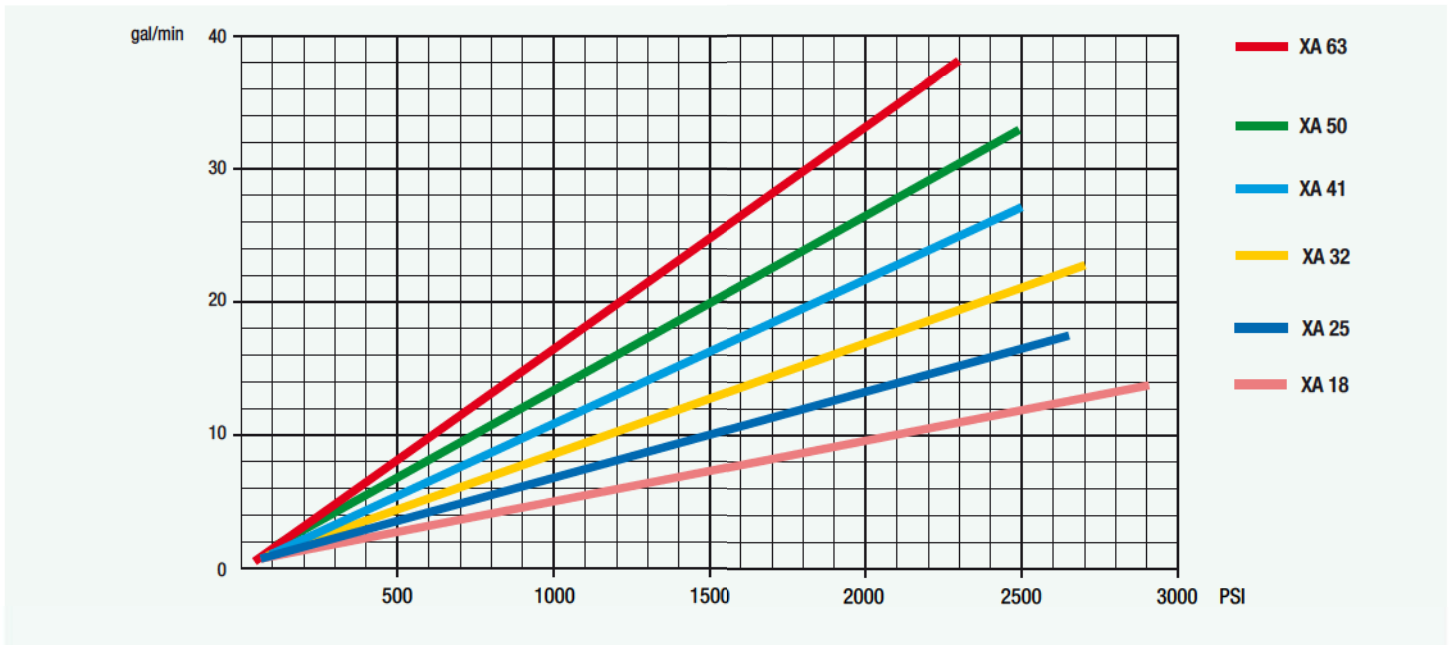

Volumetric efficiency

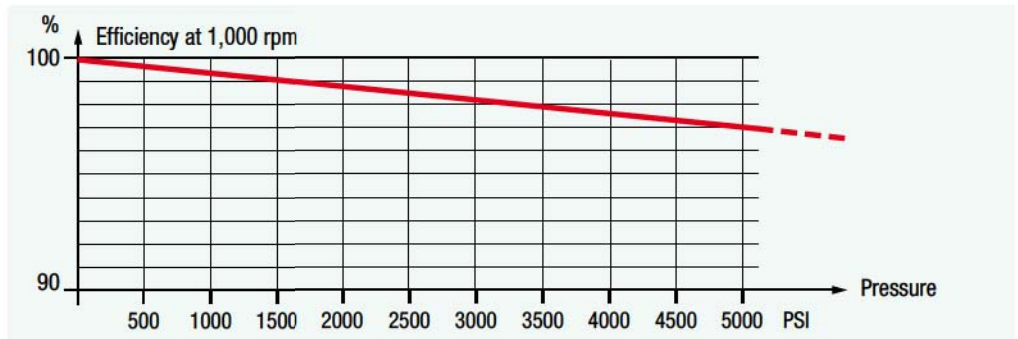

These graphs are the results of testwork done in the HL R&D laboratory, on a specific test bench, with an ISO 46 fluid at 77°F/25°C (100 cSt), the pump is fitted with an 2" HL inlet fitting, hosing is 13 feet (4 metres) long, and tank situated slightly above pump.

Accessories XA series pumps

■ By-pass valve for XA pumps

For XA pump applications where the pump is driven by a continuous running PTO (PTO which cannot be disengaged), HYDRO LEDUC offers a by-pass valve which is fitted onto the back of the pump. This solution allows the continuous running of the pump :

- without creating problems of fluid overheating ;
- without affecting pump service life ;
- with no modifications necessary to the hydraulic equipment on the truck.

■ How does it work ?

The by-pass valve is a solenoid valve (12 or 24 Volt). When not activated, it enables pump output to link up to pump inlet. When it is activated, the pump operates normally (output flow).

Pump model	12 Volt	24 Volt
XA 12 to XA 32	BPA32 0518755	BPA32 0521710
XA 41 to XA 63	BPA63 0518520	BPA63 0521715

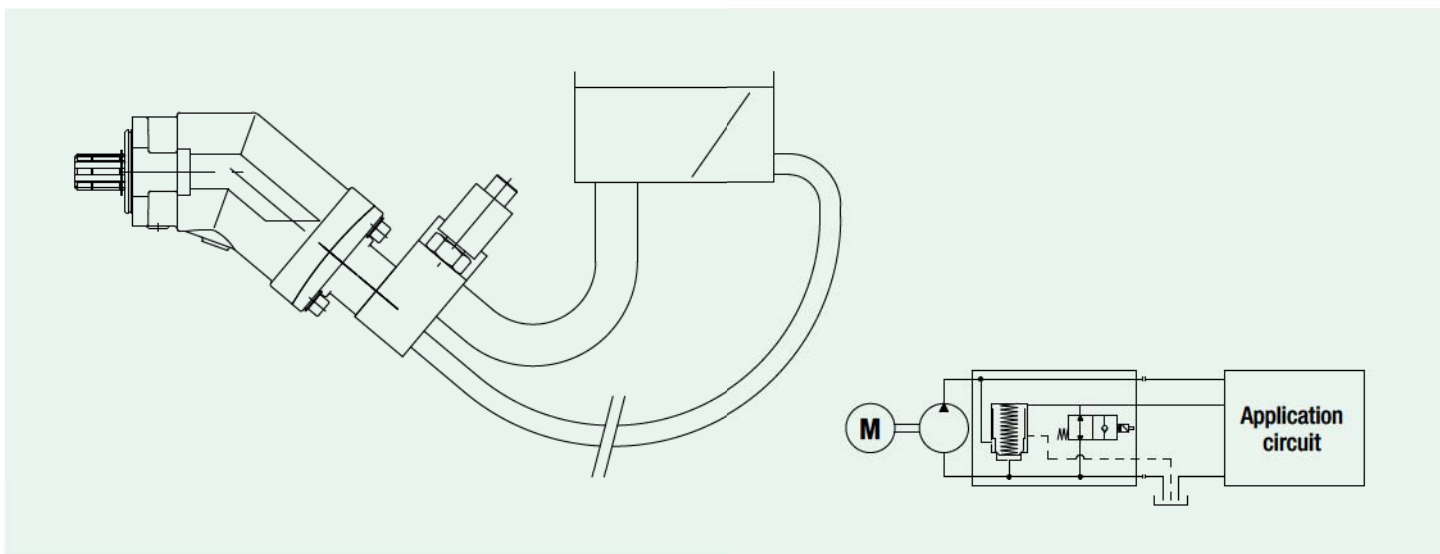

6

■ Inlet fittings for XA pumps

All XA pumps are supplied with their inlet fitting. Please specify required fitting from the choice below when ordering.

45° elbow fittings

Reference	∅ hose	∅ A	E	F
0517894	1 ½"	1.53 (39.1)	3.61 (91.7)	1.84 (46.7)
0517896	42	1.69 (43)	3.61 (91.7)	1.84 (46.7)
0517897	1 ¾"	1.80 (46)	3.61 (91.7)	1.84 (46.7)
0517893	2"	2.03 (51.8)	4.27 (108.4)	2.14 (54.4)
0517892	2 ½"	2.53 (64.5)	4.93 (125.2)	2.45 (62.2)

90° elbow fittings

Reference	∅ hose	∅ A	E	F
0517947	1 ½"	1.54 (39.1)	2.31 (58.6)	3.13 (79.5)
0517946	2"	2.04 (51.8)	2.56 (64.9)	3.16 (80.2)
0517945	2 ½"	2.54 (64.5)	2.81 (71.3)	3.44 (87.5)

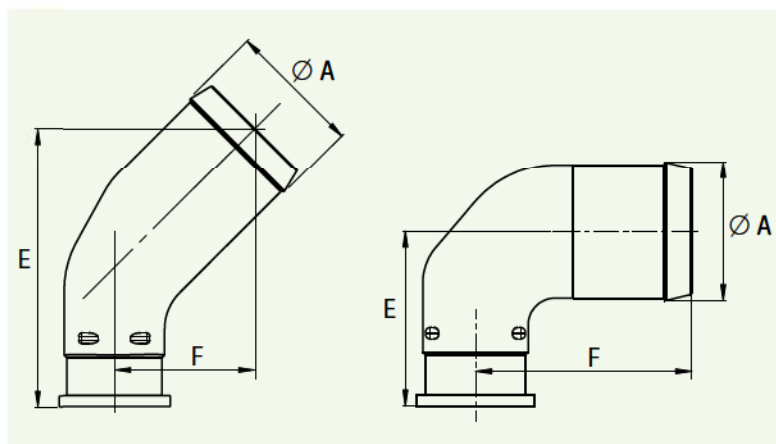

Shaft sealing XA series pumps

LEDUC pumps destined for truck hydraulics (XA, PA, PAC and TXV series) are all fitted with reinforced sealing comprising :

- two radial seals : an external seal adapted to the needs of PTOs and gearboxes; and an internal seal adapted to the needs of hydraulic performance ;
- an original protection of the pump shaft seals. This is a flexible transparent tube which avoids any entry of contaminants between the two seals, and guarantees high pressure water jet cleaning of vehicle will not damage the sealing area. It also allows air vent of the chamber between the two seals.



■ Examples of tube attachment

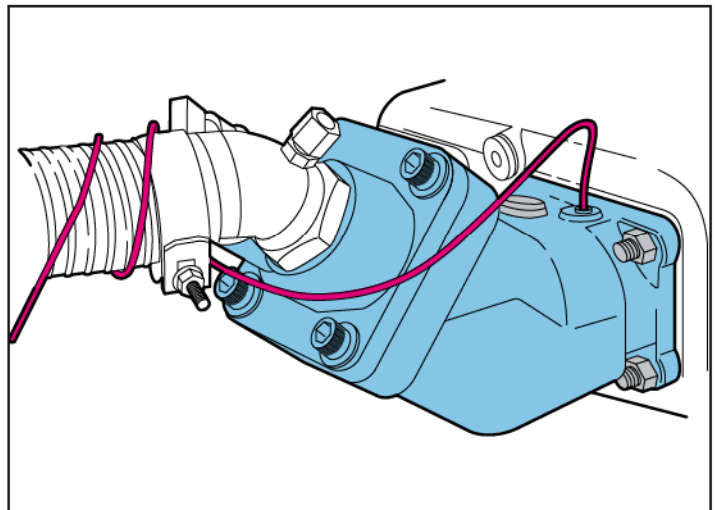
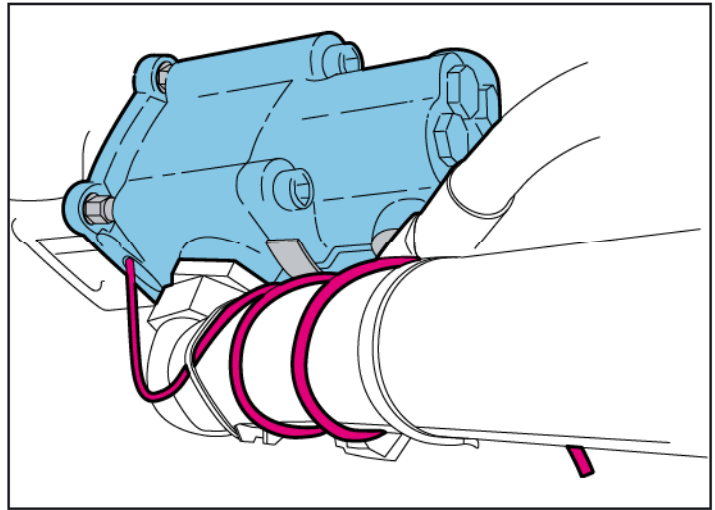

✓ Recommendations for attaching the protective tube :

- make a siphon with the tube so as to avoid any introduction of :
- dirt from road;
- water or damp from high pressure washing of vehicle;
- put the end of the tube downwards, or in a place sheltered from any projections;
- fix the tube in place using a collar/clip.

✗ Avoid :

- attaching the tube to any parts which may move, this could lead to it being damaged or torn off;
- any pinching or folds in the tube when fixing it in place;
- any obturation of the end of the tube.

 **HYDRO LEDUC stresses that on non-sealed PTO installations it is the hydraulic pump which ensures the sealing of the vehicle gearbox.**

This is why HYDRO LEDUC offers tried and tested solutions approved by vehicle manufacturers.

Note in particular the pump – PTO sealing via a frontal square section ring seal ensuring metal to metal contact between pump and PTO.



Make sure your pump lives a long happy life !

■ The tank :

Generally, hydraulic pumps much prefer a tank above the pump. Leduc pumps can also operate with oil level beneath the pump, for further information on such installations, please contact our Technical Department. Correct inlet conditions are between 11.6 to 29 psi (0.8 to 2 bar) absolute pressure.

The tank should preferably have a separation between inlet side and return. This avoids fluid emulsion and the introduction of air into the hydraulic circuit. Ensure also that the suction is not from the very bottom of the tank, so as to protect the pump from any deposits (particles).

■ Hosing :

Should be dimensioned to ensure flow between 0.5 and 0.8 m/second. Choose as direct a supply line as possible, avoiding sharp bends.

■ Filtration :

HYDRO LEDUC recommends using a very clean tank, filtered during filling and with filter on air vent.

The pump supply line must be cleaned (decontaminated) and the return line should be filtered as follows :

- for relatively simple circuits (e.g. tippers) :
use a 20 micron filter on pump return line.
- for more complex circuits (e.g. cranes) :

■ Ideal solution :

- high pressure filter between the pump and the crane hydraulic circuit ;
- 10 to 20 micron filter ;
- clogging indicato.

■ The fluid :

Use a mineral hydraulic oil with viscosity between 10 and 400 cSt. It is in this viscosity range that the pumps keep their volumetric characteristics. If you wish to use other fluids, please consult our Technical Department.

Maximum temperature of fluid in the pump should not exceed 212°F (100°C).

■ Drive and assembly recommendations :

For PTO mount applications, be careful to respect the tightening recommendations in terms of pump onto PTO and PTO onto vehicle gearbox.

XA pumps are not designed to withstand any axial load on the pump shaft. Check your installation conforms to this requirement.

■ Preparation of the pump :

For XA pumps, check the direction of rotation needed, and change it if necessary. See instructions on page 4.

Before start-up, the pumps should be filled with oil. This is essential for XA-pumps.

■ Start-up :

- open the supply valve if there is one ;
- check the valve is in "back to tank" position ;
- partially unscrew the output fitting ;
- start up at low speed, or by successive starts/stops ;
- retighten the output connector as soon as air bubbles have disappeared ;
- let the pump run for one to two minutes, and check that the flow is well established ;
- check the pump is running correctly, with no vibrations nor abnormal noise ;
- after several hours of operation, check the tightening torque of the pump fixture to PTO.

■ Maintenance :

Some regular checks are necessary, namely :

- tightening of pump to PTO ;
- cleanliness of fluid ;
- state of filter ;



if you notice traces of oil in the plastic tube, it is essential to check the sealing between PTO and pump.

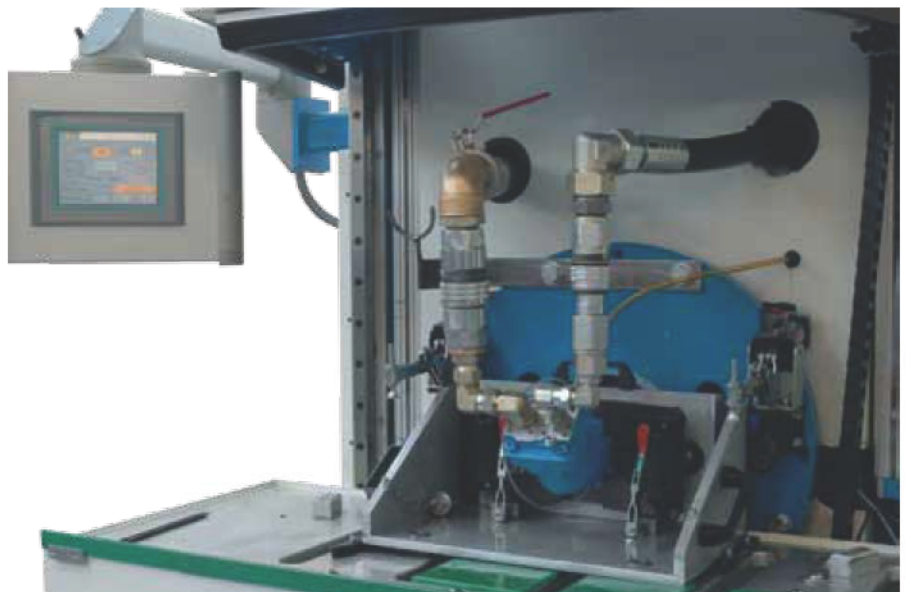

other product lines

hydraulic motors

Fixed displacement hydraulic motors with bent-axis axial pistons. Models from 18 to 125 cc. Available both in DIN and SAE versions.



Industrial applications

Fixed displacement pumps, the W series, and variable displacement pumps, the DELTA series. High pressure capabilities within minimal size. W series: flanges to ISO 3019/2, shafts to DIN 5480. DELTA series: SAE shafts and flanges.

micro-hydraulics

This is a field of exceptional HYDRO LEDUC know-how:

- axial and radial piston pumps, of fixed and variable displacement,
- axial piston micro-hydraulic motors,
- micro-hydraulic units incorporating pump, electric motors, valving, controls, etc.

To users of hydraulic components which have to be housed in extremely small spaces, HYDRO LEDUC offers complete, original and reliable solutions for even the most difficult environments.



hydro-pneumathical accumulators

Bladder, diaphragm and piston accumulators. Spherical and cylindrical accumulators. Volume capacities from 1.22 Cu.In to 13.21 gallons (20 cc to 50 liters). Pressures up to 7250 psi (500 bar). Accessories for use with hydraulic accumulators.



we are passionate about hydraulics...



A dedicated R&D team means HYDRO LEDUC is able to adapt or create products to meet specific customer requirements. Working in close cooperation with the decision-making teams of its customers, HYDRO LEDUC optimizes proposals based on the specifications submitted.

A passion for hydraulics

HYDRO LEDUC

Head Office & Factory
BP 9 - F-54122 AZERAILLES (FRANCE)
Tél. +33 (0)3 83 76 77 40
Fax +33 (0)3 83 75 21 58

HYDRO LEDUC GmbH

Haselwander Str. 5
D-77746 SCHUTTERWALD (DEUTSCHLAND)
Tel. +49 (0) 781-9482590
Fax +49 (0) 781-9482592

HYDRO LEDUC N.A., Inc.

19416 Park Row - Suite 170
HOUSTON, TEXAS 77084 (USA)
Tel. +1 281 679 9654
Fax +1 832 321 3553



Complete catalogues available at:
www.hydroleduc.com



HYDRO LEDUC

SAS with capital of 4 065 000 euros

Siret 319 027 421 00019

RC Nancy B 319 027 421

mail@hydroleduc.com

 **HYDRO
LEDUC**
TOHIO[®]